

HONG KONG HOCKEY ASSOCIATION – WOMEN’S SECTION

COMPETITION BYE-LAWS

CONTENTS

1. Definitions
2. Authority of HKHA Women’s Section Committee
3. Alteration to the Competition Bye-laws of the HKHAWS
4. Teams
5. Player Registration
6. Visiting Players
7. Player Movement
8. Player Transfer
9. Team Uniforms
10. League Organisation
11. League Matches
12. Postponements/Cancellations/Abandonments
13. Captains’ Responsibilities
14. Match Cards
15. Domestic Tournaments
16. Misconduct, Complaints and Appeals
17. Responsibility of Teams to Provide Umpires
18. Advertising on Uniforms
19. Charges & Levies
20. Trophies
21. Unforeseen Events

SCHEDULES

First Schedule	Fees
Second Schedule	Penalties and Fines
Third Schedule	Yellow and Red Cards
Fourth Schedule	Advertising on Uniforms

1. **DEFINITIONS**

1.1. In these Bye-laws, unless the context otherwise requires, the following words and expressions shall have the following meanings:

Affiliated Club	A club, association or team that is affiliated to the HKHAWS.
Articles of Association	The Articles of Association of the HKHA
Bye-laws	These competition bye-laws.
Committee	The committee of the HKHAWS.
Convenor	Person nominated by an Affiliated Club as the appointed representative empowered to communicate with the Committee.
Disciplinary Committee	The Disciplinary Committee appointed by the Hong Kong Hockey Association.
Division	The meaning ascribed to such term in Bye-law 10.1.
Electronic Match Card	A match card in such electronic form as shall be determined by the HKHAWS.
FIH	International Hockey Federation.
General Bye-laws	The general bye-laws of the HKHAWS.
HKHA League	The meaning ascribed to such term in Bye-law 10.1.
HKHA Team	Any team in the HKHA League registered by the HKHA Veterans Section, the HKHA Promotion and Development Section or the HKHAWS.
HKHAWS	The Hong Kong Hockey Association – Women’s Section.
Knockout Tournaments	The meaning ascribed to such term in Bye-law 15.1.
Match Card	An Electronic Match Card or a Paper Match Card as the case may be.
Match Official	Those nominated or designated to officiate at matches held under the auspices of the HKHA.
Nominated Player	The meaning ascribed to such term in Bye-law 4.3.
Paper Match Card	A match card in such physical form as shall be determined by the HKHAWS.

Rules of the HKHA	The rules promulgated by the HKHA and made available on the website of the HKHA.
Team Captain	The player who has signed a Paper Match Card or completed an Electronic Match Card, in either case in their capacity as captain, pursuant to Bye-law 14.1(e) or 14.2(e) as applicable.
Team Official	Captain, team coach, manager, assistant manager, trainer or doctor/ physiotherapist.
Umpire	Those nominated or designated to umpire matches held under the auspices of the HKHA.
Umpire Number	The number allocated to each Umpire by the HKHA Umpires Section.

- 1.2. Capitalised terms used herein that are not defined shall have the meaning ascribed to such term in the Articles of Association.
- 1.3. Words denoting the singular shall include the plural and vice versa.
- 1.4. References to any articles, rules, regulations, bye-laws or any other documents shall be construed as relating to such articles, rules, regulations, bye-laws or any other documents as amended, supplemented, amended and restated or otherwise modified from time to time.

2. AUTHORITY OF HKHA WOMEN'S SECTION COMMITTEE

In accordance with and subject to the Articles of Association and the General Bye-laws, all issues concerning women's hockey in Hong Kong are under the sole authority of the Committee.

3. AMENDMENTS TO THESE BYE-LAWS

- 3.1. The Committee may make amendments to these Bye-laws from time to time. Affiliated Clubs shall be given fourteen (14) days to comment on the proposed changes.
- 3.2. The Committee may introduce experimental Bye-laws from time to time. Affiliated Clubs shall be given fourteen (14) days to comment on the proposed changes.
- 3.3. These Bye-laws, and any amendments, shall be submitted to and approved by the HKHA Council before implementation.
- 3.4. The Secretary shall furnish the Convenor of each Affiliated Club with a copy of these Bye-laws within twenty-one (21) days of any amendments.

4. TEAMS

- 4.1. Affiliated Clubs of the HKHAWS may apply for one or more teams to be entered in the HKHA League. Each team shall have a minimum of fifteen (15) registered players and no more than thirty (30) players, who may be registered for one team. However, if a team registers more than twenty-two (22) players, an administrative fee (as per First Schedule) shall be charged per player from the twenty third (23rd) player onwards irrespective of whether players are de-registered at a later date. A player may only be registered for one Affiliated Club team at any one time, but may also be a member of a team in the Veterans Section or the Promotion and Development Section.
- 4.2. Multi-team Affiliated Clubs shall enter teams in the HKHA League, cup, festival and other tournament matches organised by the HKHAWS in ranking order of A, B, C, D etc. The strongest team, based upon merit and playing strength of players therein, shall be the highest ranked and shall be called the 'A' team. The B, C, D, etc., teams shall follow in order of strength based upon the criteria for A team players. The Committee shall monitor this aspect, and may, at its sole discretion, take disciplinary action against any Affiliated Club, which it believes to have abused the intention of these Bye-laws. Players who have played hockey at international, state, provincial or equivalent level within the last two years must be registered in the "A" team of their Affiliated Club unless prior dispensation is granted by the Committee.
- 4.3. Notwithstanding Bye-law 4.1, at the time of registration (or any time thereafter, subject to seven (7) days' prior written notice to the Committee), an Affiliated Club may nominate a player (a "**Nominated Player**") to be registered as a nominated goalkeeper for one Club team and as a field player for another team of the same Affiliated Club provided that (i) the two (2) Club teams in which the Nominated Player is registered are in separate divisions, (ii) the written notice clearly states the Club team for which the Nominated Player is a nominated goalkeeper and the Club team for which the Nominated Player is a field player, (iii) the Nominated Player will not play as a goalkeeper or as a field player for any Club team other than as specified in the aforementioned written notice (unless otherwise agreed by the Committee).
- 4.4. No team may have more than one (1) Nominated Player registered as a nominated goalkeeper of such team at any time (unless otherwise agreed by the Committee). However, an Affiliated Club may, subject to seven (7) days' prior written notice to the Committee, cancel the nomination of a Nominated Player and nominate a new Nominated Player in accordance with Bye-law 4.3 above.

5. **PLAYER REGISTRATION**

- 5.1. Each Affiliated Club shall ensure that only registered hockey players of that Affiliated Club take part in hockey matches held under the auspices of the HKHA. A person shall not be considered for registration unless the HKHAWS Player Registration application form is correctly completed, signed and has the necessary supporting documentation. (This includes a copy of an HKSAR Identity Card or a receipt for the application of one, and an electronic copy of her personal portrait as specified by the HKHAWS). The registration fee, as specified in the First Schedule shall accompany the application, if appropriate.
- 5.2. New players that have not registered previously with the HKHAWS must provide a signed declaration which states that they are not currently serving any suspensions

or under disciplinary action and that they understand associated liabilities of playing hockey in Hong Kong.

- 5.3. No player may be registered unless she has reached her twelfth (12th) birthday. Players who have not reached their eighteenth (18th) birthday on the first day of September in the then current HKHA League season shall have the agreement of a parent or legally appointed guardian as specified in the HKHAWS Player Registration application form and provided such application form correctly completed and signed together with any necessary supporting documentation.
- 5.4. The Committee may waive certain requirements of Bye-Law 5.3 for teams entered in the HKHA League by the HKHA Promotion and Development Section.
- 5.5. All re-registering players must sign a declaration annually to indicate that all player details are correct and that players understand associated liabilities of playing hockey in Hong Kong.
- 5.6. The Committee may refuse the registration application in respect of any player who had been suspended more than once in the preceding season.

Contravention

- 5.7. A penalty, as specified in the Second Schedule, shall be levied for a contravention of these Bye-laws.

6. VISITING PLAYERS

- 6.1. Each Affiliated Club is permitted to register a maximum of three (3) players NOT in possession of a valid Hong Kong Identity Card per HKHA League team. These players are referred to as 'visiting players'. An administrative fee (as per First Schedule) shall be charged per visiting player registered.
- 6.2. A visiting player shall only play for the team she is registered for within the Affiliated Club. In other words, the visiting player cannot move among teams within the same Affiliated Club without prior approval from the Committee. Each League team is permitted to list and play a maximum of two (2) visiting players in any match.
- 6.3. Visiting players are NOT eligible to play in the last two (2) League matches of their registered teams, nor in any Knockout Tournament matches. However, these restrictions shall be lifted once the visiting player has played a minimum of three (3) consecutive matches for her registered team and the Affiliated Club concerned is responsible to inform the Committee prior to the visiting player taking part in the last two (2) League matches or Knockout Tournament matches (as the case may be). No registration of visiting players shall be permitted between the first (1st) day of February and the end of the HKHA League.
- 6.4. A visiting player must play a minimum of three (3) consecutive matches in the season for her registered team. In the event that the player fails to comply with this requirement, penalties shall apply as per the Second Schedule, unless the player was physically unable to play because of injury or ailment **and** this is corroborated by the delivery of a medical report or certificate issued by a medical practitioner registered

with the Hong Kong Medical Council or equivalent foreign body acceptable to the Committee, certifying that she was injured and unfit to play the required number of matches to fulfil the three (3) consecutive match undertaking.

- 6.5. Visiting players being registered in Premier Division must provide a “**Letter of No Objection**” issued by the national hockey association of the last country they played for. The No Objection Certificate must be valid for a period of time that is sufficient enough to enable the player concerned to fulfil the three (3) consecutive match undertaking in Bye-law 6.4.
- 6.6. Affiliated Clubs or teams who have registered visiting players bear full responsibility for the conduct of these registered visiting players. The visiting player’s Affiliated Club shall pay any fines levied as a result of any misconduct of a visiting player.

Contravention

- 6.7. If any team is subject to any penalties under this Bye-law, the Committee may, at its sole and absolute discretion, lower the maximum number of visiting players the subject team can register in a single season in the future.
- 6.8. A penalty, as specified in the Second Schedule, shall be levied for a contravention of these Bye-laws. The Committee will monitor the use of visiting players and reserves the right, at its sole discretion, to take disciplinary action against any Affiliated Club found abusing the privileges of Bye-laws 6.1-6.6 inclusive.

7. PLAYER MOVEMENT

- 7.1. No player, including a listed substitute (even if she does not actually take part in the earlier match), may play for more than one (1) team on any one (1) match day including goalkeepers playing outfield without the prior approval of the Committee unless:
 - (a) she is a Nominated Player who on one (1) match day played (i) as goalkeeper in the team in which she is a nominated goalkeeper and (ii) as a field player in the team in which she has been registered as a field player; and
 - (b) the use of the abovementioned exception is clearly recorded on the Match Cards of both matches in which the Nominated Player was registered by the respective Team Captains of the teams in which the Nominated Player played (including indicating whether she will play in goal or as a field player), and notified to each Umpire, Team Captain and if applicable, Match Official, prior to the start of the match.
- 7.2. Each player shall be registered for one specific team which she plays as her designated team (save as provided for in Bye-laws 4.3 and 4.4 above). A player:
 - (a) who has registered for a higher-ranked team cannot play for a lower-ranked team without first obtaining the approval of the Committee.
 - (b) who has registered for a lower-ranked team may only play for a higher-ranked team for a maximum of three (3) matches during the same HKHA

League. This includes league, cup and tournament matches. For the avoidance of doubt, one-day divisional tournaments shall be deemed to constitute one (1) match for the purposes of this Bye-law 7.2. Once she has played four (4) matches for higher-ranked teams, she will be automatically registered for the highest-ranked team that she has played for and cannot play for any other team thereafter without the prior approval of the Committee.

- 7.3. All player movements must be recorded on the Match Card by the respective Team Captains prior to the start of a Match.
- 7.4. No player movement is allowed between any team in the Premier Division and the lower-ranked teams in their respective Affiliated Club until both (or more) teams involved have completed their first two (2) matches of the HKHA League. For the avoidance of doubt, this provision does not apply among teams outside the Premier Division.

Player Movement in Knockout Competitions

- 7.5. No player who at any time during the current League season has been registered for a Premier Division team shall be eligible to play in any Knockout Tournament other than the Guv Dillon Cup.
- 7.6. A lower-ranked player may play for a higher-ranked team in the Guv Dillon Cup or other Knockout Tournament, subject to Bye-law 7.2(b).
- 7.7. No player may play in a Knockout Tournament match unless she has participated in at least two (2) league matches with any team of the Affiliated Club with whom such player is currently registered.
- 7.8. Once a player has participated for a team in one of the Knockout Tournaments, she cannot play for another team in any Knockout Tournament without the Committee's approval.

Contravention

- 7.9. A penalty, as specified in the Second Schedule, shall be levied for a contravention of these Bye-laws.

8. PLAYER TRANSFER

- 8.1. Should a player wish to transfer from one Affiliated Club to another during the HKHA League, the Convenor of the player's current Affiliated Club shall (i) make this intention known by written communication to the Committee and (ii) release the player in the online registration system.
- 8.2. The Convenor for the Affiliated Club that the player is moving to should then apply to the HKHA to move the player profile within the online registration system to the new Affiliated Club.
- 8.3. Until registration of the player with the Affiliated Club that the player is moving to has been approved and completed by the HKHA, including payment of the

appropriate fee, as specified in the First Schedule, the player concerned shall not play hockey for either Affiliated Club, in any match, held under the auspices of the HKHA. She may, however, play for an HKHA Team.

- 8.4. Should the current Affiliated Club refuse to release the player within a reasonable time, but in any case no longer than five (5) working days from the date of an official request from the Convenor of the player's proposed new Affiliated Club to the Committee, the player may appeal to the Committee for the transfer to be approved. In the event of such unreasonable delay, the Committee may manually release the player and require the player's previous Affiliated Club to pay the transfer fee.
- 8.5. The Convenor of the proposed new Affiliated Club of a player who wishes to transfer from one Affiliated Club to another for the second time within the same season shall be required to seek the prior approval of the Committee.
- 8.6. No transfer of players between Affiliated Clubs shall be permitted between the first day of February and the end of the HKHA League.

9. TEAM UNIFORMS

- 9.1. Affiliated Clubs shall submit their team uniform designs for the Committee's approval each year when they submit their league registration form. The colours of the first and second strips should be distinctively different for the shirt and the socks. Failure to do so will be considered as an incomplete registration and will therefore be subject to a late registration fee should the completed form not arrive before the deadline set by the Committee.
- 9.2. Teams shall play in the shirt, skirt and sock colours as stated on their HKHAWA application form and approved by the Committee.
- 9.3. Goalkeepers shall wear, over any upper body protectors, a shirt or garment of a colour different from that of their own team and of their opponent.
- 9.4. The Committee shall advise all Convenors of these colours before the start of the HKHA League. In the event of a clash of colours, the second-named team on the fixture, being the "away" team, shall change their shirts and/or socks. Teams should note that a clash of sock colours might occur even though there is no clash of shirt colours.
- 9.5. No Affiliated Club may use white coloured socks for either their first or second strip and should refrain from including white in their socks design.
- 9.6. No team may use yellow as an official colour for its shirts. This colour is reserved for the exclusive use of the HKHA Umpires Section.
- 9.7. The HKHA logo is the official designation for the uniform of players and officials of the HKHA selected to represent the HKHA or Hong Kong at representative hockey matches. Affiliated Clubs shall ensure that their members do not display the HKHA logo on any item whatsoever unless with the express permission of the HKHA Council. The HKHA Council will view any breach of this Bye-law as a most serious matter.

- 9.8. A player may not participate in any League, Cup or Tournament match organised by the HKHAWS unless she is:
- (a) wearing a numbered shirt with such number conforming to her Player Registration number and shall be clearly printed or sewn on the fabric itself at the back of the shirt and should meet the following requirements:
 - (i) the colour should be in contrast to the shirt colour;
 - (ii) the number should be in a distinctive filled (not outlined) figure(s)/font(s);
 - (iii) the size should be not less than 16 cm and not more than 20 cm in height on the back of the player/goalkeeper's shirt;
 - (b) wearing shin guards, properly tucked inside her socks; and
 - (c) wearing suitable footwear (football boots with studs for grass pitch shall not be worn on artificial-turf pitches).
- 9.9. Undergarments (such as leggings or long sleeved shirts) worn during matches by any player should match adjoining playing kit colours as much as possible. If not, only solid white or black colours are acceptable alternatives. Players should be prepared to remove their undergarments if such undergarments are adjudged by Umpires to be causing confusion to their umpiring work.

Note: Players are advised to remove all accessories during matches to avoid causing injuries.

- 9.10. Team Captains must wear a distinctive arm-band or similar distinguishing article on an upper arm, shoulder or lower leg.

Contravention

- 9.11. A penalty, as specified in the Second Schedule, shall be levied for a contravention of these Bye-laws.

10. LEAGUE ORGANISATION

- 10.1. The HKHA's league competition for the HKHAWS (hereinafter the "**HKHA League**") normally comprises:
- (a) A Premier Division;
 - (b) A First Division;
 - (c) A Second Division;
 - (d) A Third Division;
 - (e) A Fourth Division; and
 - (f) A Fifth Division,
- (each being a "**Division**").

- 10.2. The competition and rules for the Premier Division may be subject to a pre-season meeting of the Committee with the local Premier Division teams of the immediately completed season and any other teams invited by the Committee.
- 10.3. The number of Divisions and number of teams playing therein may be varied by the Committee prior to the commencement of each League season to take into account of prevailing circumstances at the time, such as number of new teams entered, old teams dropping out, capacity of hockey pitches available for League matches etc.
- 10.4. The HKHAWS may accept teams from the HKHA Veterans Section and HKHA Promotion and Development Section, to participate in the HKHA League. Such teams shall only be accepted on condition that they abide by all relevant HKHAWS Bye-laws. The Committee shall decide in which Division such a team shall play. The results of HKHA League matches involving these teams will count for all purposes, except that the final placing of these teams will be disregarded for purposes of determining the HKHA League winners.
- 10.5. New teams shall start in the lowest Division unless the Committee decides otherwise.
- 10.6. New teams wanting to enter a higher Division must demonstrate to the Committee that the team has eight (8) or more players that have been registered for a team in the same division, or higher, in the preceding two seasons. Such teams may be placed in that division as determined by the Committee.
- 10.7. No new team will be accepted once the HKHA League has commenced.

Promotion and Relegation

- 10.8. Points for league matches will be awarded as follows:
 - (a) Win: Three (3) points
 - (b) Draw: One (1) point
- 10.9. Where two or more teams have an equal number of points, they will be ranked according to the following criteria (in order):
 - (a) Matches won
 - (b) Goal difference
 - (c) Goals for
 - (d) Results between equal teams in the competition
- 10.10. The winner and first runners-up teams in the First, Second, Third, Fourth and Fifth Divisions shall be eligible for promotion to the Premier, First, Second, Third, and Fourth Divisions respectively for the following HKHA League season.
- 10.11. The lowest and second lowest ranking teams in the Premier, First, Second, Third and Fourth Divisions may be relegated to the next lower division.
- 10.12. If there is still a tie (after taking into account Bye-law 10.9) between two or more teams competing for promotion, the teams shall be declared joint winners of that Division.

- 10.13. Notwithstanding Bye-laws 10.10 to 10.12 above, the Committee's decision on the Divisional composition shall be final. The Committee's decision will be communicated to Affiliated Clubs at the start of each hockey season, including the promotion and relegation criteria.

11. LEAGUE MATCHES

- 11.1. All matches shall be played in accordance with the Rules of Hockey, as issued by the FIH unless otherwise notified by the HKHAWS.
- 11.2. All matches shall commence at the scheduled time as stated in the fixtures list. In the event of a late start (i.e. after ten minutes of the scheduled time) where the fault lies with one or both teams (e.g. late completion of a Match Card, goalkeeper not ready etc.) the Umpire shall record this on the Match Card. The match playing time may be cut short into four equal quarters in order for the next game to start on time or for the pitch to be handed over in time to LCSD for the next booking. This must be communicated by the Umpires to the Team Captains at the start of the match.
- 11.3. Should the entire team, for whatever reason, walk off (or refuse to continue to play), the match shall be awarded to its opponents four (4) goals to nil, or the score at the time, whichever is the higher. The Team Captain involved is required to submit a report to explain the walk off decision to the Committee within forty-eight (48) hours of the incident. The Committee will investigate the incident and refer the case to the Disciplinary Committee for follow up action, where necessary.

Regular 11-a-side Matches

- 11.4. Teams shall, at the start of a match, consist of at least eight (8) registered players. In the event that a team (or teams) does not have at least eight (8) players on the field of play within ten minutes of the scheduled time for the start of the match, such team (or teams) will be in breach of this Bye-law, the match will not be played and the Umpires will record the result as a WALKOVER on the Match Card. The team receiving the walkover will be awarded the game four (4) goals to nil.
- 11.5. In any regular competition (11 players on the field), if for any reason, the number of players of a team is reduced to less than eight (8) players, at the time that happens, the match shall be awarded to the opponents four (4) goals to nil, or the score at the time, whichever is the higher. The Umpires will report the reason for the above, and if there is any question of players walking off, as opposed to injury or dismissal (red card), the matter will be referred to the Committee. For the avoidance of doubt, a player who has been shown a Yellow Card continues to be a player. A player who has been shown a Red Card immediately ceases to be a player.

Walkovers/Withdrawals

- 11.6. A team which gives two (2) walkovers during the HKHA League (or a team in the Premier Division which gives one (1) walkover during the HKHA League) or one (1) walkover during the Knockout Tournaments may be required to withdraw from the HKHA League and/or the Knockout Tournaments by the Committee. In the event of such a withdrawal all previous results of that particular team in the HKHA League and/or the Knockout Tournaments will be nullified. The Convenor of an Affiliated

Club which has given a walkover in any HKHA match is required to explain in writing to the Committee, within seven (7) days of the date of the match, the reason(s) for the team having given the walkover.

- 11.7. If a team withdraws from the HKHA League or the Knockout Tournaments at any time, the Committee shall have discretion to impose such penalty on that particular team as they deem necessary.

Contravention

- 11.8. A penalty, as specified in the Second Schedule, shall be levied for a contravention of these Bye-laws. Note that different penalties apply to different contraventions.

Request for Postponement or Bringing Forward of Matches

- 11.9. Requests for postponement or bringing forward of a match on the grounds of player unavailability will normally not be entertained. However, the Committee may consider a request for postponement or bringing forward of a match if the request is made at least fourteen (14) days before the match is scheduled to take place. The Committee will advise the Affiliated Clubs within five (5) days whether their application has been granted. Requests for postponement or bringing forward shall be accompanied by an administrative levy, as specified in the First Schedule, which may be refunded at the Committee's discretion.
- 11.10. Any match in which a team has three (3) or more players absent because of national team duty for the HKHA Squads (including as a Team Official) may be postponed if a request is made at least fourteen (14) days before the match is scheduled to take place and the Committee exercising its sole discretion, approves such request.

12. POSTPONEMENTS/ CANCELLATIONS/ ABANDONMENTS

- 12.1. If an artificial-turf pitch has been inadequately watered (either by the spray system or naturally by rain), the Umpires shall make a decision on whether the match shall commence. If the match is cancelled because of this, the Umpires shall record this on the Match Card.
- 12.2. To be acceptable for play, the playing surface shall have received sufficient water to be thoroughly wet, taking account of the prevailing weather conditions.
- 12.3. The two teams shall not play a "**friendly match**" on the surface. If they do, they will be charged the cost of the pitch booking and may be subject to disciplinary action by the Committee.
- 12.4. In the event that a black rain storm signal or a typhoon signal number 8 or above is in force at the appointed starting time, the match shall not commence.
- 12.5. In the event of a thunderstorm warning, and the authorities in charge of the pitch have not closed it, play shall commence/continue until the conditions are not safe for players and officials to stay outdoors. At that point the Umpires shall temporarily stop the match (noting the time remaining) and all players and officials shall immediately leave the pitch area to seek shelter. When the storm has passed (and if

permitted by the ground authorities) the match shall be restarted as directed by the Umpires, taking account of the play situation at the moment of stoppage.

- 12.6. In the event that heavy rain causes an artificial-turf pitch to become so waterlogged that play becomes difficult or even dangerous, the Umpires shall temporarily stop the match (noting the time remaining) and wait until the worst of the storm has passed and the pitch drained to a satisfactory condition. The match will then be restarted as per Bye-law 12.5.
- 12.7. For natural grass pitches, the decision on whether play may proceed rests with the venue's authority. However, over matters of player safety, such as during a thunderstorm, the Umpires shall take responsibility.
- 12.8. In the event of a failure of the floodlighting during an evening match, the Umpires shall immediately stop the match. If the fault cannot be rectified within a short time, and the match restarted as per Bye-law 12.5, the Match Card shall be completed noting that the match was abandoned and the time remaining. The Committee shall then decide on the appropriate action.
- 12.9. The Convenor for the home team shall notify the Committee by telephone or email on the day following that on which League matches have been postponed or abandoned due to inclement weather. The Committee shall reschedule the playing of these postponed or abandoned League matches at the earliest opportunity.
- 12.10. Due to adverse playing conditions arising from any of the circumstances described in Bye-laws 12.1 or 12.4-12.8, the Umpire may decide to abandon a match. Should the match be abandoned during the first half, the full match will be rescheduled to another time by Committee and NO score shall be carried forward to the rescheduled match. Red and/or Yellow cards issued will however be counted against the player's disciplinary record. Should the match be abandoned after the completion of the first half, the score at the time will be counted as the final score with no rescheduling of the match.

13. CAPTAINS' RESPONSIBILITIES

- 13.1. Each Team Captain has authority only over her own listed team players; she has no right to question or challenge any decisions made by the Umpires. Should a match Umpire call upon a Team Captain to give instructions to her team, the Team Captain shall do so immediately.
- 13.2. In the event that no Umpires are present at the scheduled time for commencement of a match, both Team Captains shall act as umpires or may designate qualified individuals to act as umpires. Each Team Captain shall, therefore, have a whistle in her possession at each HKHA match. In the event that only one qualified Umpire is present at the scheduled commencement of a match, it is the responsibility of the two Team Captains and the Umpire to reach a mutually acceptable agreement as to the provision of the second qualified Umpire. If this agreement is not forthcoming, each team shall provide one non-playing qualified umpire for one half of the match. In case either team or both teams cannot provide non-playing qualified umpire, the Team Captains have to either umpire for their respective teams or appoint one of their players who is qualified to umpire for the subject match.

13.3. Team Captains are responsible and held accountable for the completion and the accuracy of the information of their respective teams on Match Cards.

13.4. Team Captains are responsible for fielding her team with eligible players only.

Contravention

13.5. A penalty, as specified in the Second Schedule, shall be levied for a contravention of these Bye-laws.

14. MATCH CARDS

14.1. If the HKHAWS has informed Affiliated Clubs that Paper Match Cards will be used for the coming season:

- (a) The home team is the first named of the two teams in a match. Before the commencement of a HKHAWS match, the home Team Captain shall fill out a Paper Match Card in block letters, in ink or ball point, stating the particulars of the match (League, Division, Venue, Date, etc.), the names of all her team players and their Registration Numbers, up to a maximum of sixteen (16) players. The completed Paper Match Card shall be passed to the away Team Captain at least 15 (fifteen) minutes prior to the scheduled match start time.
- (b) On receipt of the Paper Match Card, the away Team Captain shall fill in, in block letters, in ink or ball point, the names of all her team players and their Registration Numbers, up to a maximum of sixteen (16) players. The completed Paper Match Card shall be passed to the Umpires at least five (5) minutes prior to the scheduled match start time.
- (c) In the event that an Umpire fails to arrive at a match on or before the scheduled starting time, the home Team Captain shall make a note of this fact on the Paper Match Card.
- (d) After the match, the Umpires shall record the final result on the Paper Match Card, together with details of any Bye-law contravention and Yellow and/or Red Card awards.
- (e) The Umpires shall sign the card as a true record of the players taking part and of the result of the match, etc. and then both captains shall sign, before returning the Paper Match Card to the Home Team Captain. Upon signing the Paper Match Card, the team captain is deemed to have accepted the information recorded on the Paper Match Card as accurate and final. Should one of or both captains disagree with the information on the Paper Match Card, they should make note on the Paper Match Card in the area provided and submit a written report to the Committee within three (3) days of the match.
- (f) The home Team Captain shall promptly post the original Paper Match Card to the HKHA office, no later than three (3) days after the match.

- (g) Within forty-eight (48) hours of the completion of the match, the home Team Captain or Convenor has to send the image files of both sides of the completed Paper Match Card via email to the HKHAWS. Both Team Captains should take pictures of the completed Paper Match Card for future reference in case of any dispute regarding the information on the Paper Match Card. For the avoidance of doubt, the email of the image files of the Paper Match Card does not waive the responsibility of the home Team Captain in sending the Paper Match Card to the HKHA office as stipulated in Bye-law 14.1(f) above.

14.2. If the HKHAWS has informed Affiliated Clubs that Electronic Match Cards will be used for the coming season:

- (a) The home team is the first named of the two teams in a match. Before the commencement of a HKHAWS match:
 - (i) the home Team Captain shall select the names of all her team players, up to a maximum of sixteen (16) players, insert the Umpire Numbers of the officiating Umpires for the match and then click “submit player list” in the electronic match card;
 - (ii) the away Team Captain shall select and confirm electronically the names of all her team players, up to a maximum of sixteen (16) players; and
 - (iii) the Umpires will not commence the match until steps (i) and (ii) above have been completed.
- (b) In the event that an Umpire fails to arrive at a match on or before the scheduled starting time, the home Team Captain shall make a note of this fact on the Electronic Match Card.
- (c) After the match:
 - (i) the Captains shall ensure that, immediately after the match the Umpires enter the final result in the Electronic Match Card, and click “Submit Match Card” after inserting, if any, the details of any Bye-law contravention and Yellow and/or Red Card awards, then
 - (ii) each Team Captain will identify in the Electronic Match Card any players in their Team who scored a goal in the match and the number of goals scored, insert additional comments, if any, (including as may be required pursuant to 14.2(b)) and click “Submit Match Card” within twenty four (24) hours of the scheduled start time of the match.
- (d) If the Electronic Match Card cannot be completed due to a technical issue, the home Team Captain shall provide a sheet of paper on which both Team Captains will enter player lists and the Umpires will sign off with results and additional information/comments, if any, inserted. This sheet of paper shall be treated as a Paper Match Card and steps set out paragraphs 14.1 (d) to (g) must be complied with.

- 14.3. The responsibility of checking the Team's Players List and players' photographic identifications rests jointly with the officiating Umpires and the Team Captains. In the event of dispute/disagreement between the two Team Captains, the officiating Umpires shall make the decision and a note to that effect recorded on the Match Card. In order to facilitate a proper and efficient player identification check, all players are required to carry with them their photographic identification documents or a copy thereof.
- 14.4. Both Team Captains shall provide the Umpires with their respective most updated Team Players Lists with pictures for all players listed on the Match Card at least 5 (five) minutes prior to the scheduled match start time. In the event a team is unable to produce the Team Players List with pictures, the Umpire may demand a photographic identification check on players to be carried out before or during the match. In the event that a team is unable to produce photographic identification for particular players, the Umpire should note which players were unable to produce photographic identification on the Match Card for action by the Committee. A player who has failed to provide a photographic identification document upon request will be deemed an unregistered player.

Contravention

- 14.5. A penalty, as specified in the Second Schedule, shall be levied for a contravention of these Bye-laws. Note that different penalties apply to different contraventions.

15. DOMESTIC TOURNAMENTS

- 15.1. The tournaments approved by HKHAWS include the Knockout Tournaments (being the Guv Dillon Cup, Knockout Cup and the derivatives of the Knockout Cup, hereinafter the "**Knockout Tournaments**"), one-day and other tournaments as sanctioned by HKHAWS from time to time.
- 15.2. Unless otherwise specified, all teams (except HKHA Teams) are automatically entered into domestic tournaments organised by the HKHAWS.
- 15.3. The normal rules of hockey and these Bye-laws shall apply to all tournaments except as per the following Bye-laws.
- 15.4. If a team withdraws from domestic tournaments at any time, the Committee shall have the discretion to impose such penalty on the offending team as it thinks fit.

Knockout Tournaments

- 15.5. The Committee shall determine which teams will take part in the different Knockout Tournaments based, amongst other things, on team rankings at the end of the first round of the current League.
- 15.6. Convenors shall be advised in writing which competition the teams will take part in by the Committee.

15.7. Seeding

- (a) Teams eligible for the tournament will be seeded by the Committee based on the team performances in the current League.
- (b) The draw shall provide that the top four seeded teams in each tournament will not meet in the preliminary round.

15.8. Current Premier Division rules shall apply to all knockout Guv Dillon Cup games.

15.9. If the format of any Knockout Tournament includes a Round Robin stage, the rules in Bye-law 15.12(b) and (c) shall apply.

15.10. If there is still a tie after considering Bye-law 15.12(c), a play-off game will be played as soon as practically possible to determine the ranking.

15.11.

In the event of a draw in all knockout rounds up to and including the -final, the match winners shall be determined by a Penalty Shootout Competition. The Penalty Shootout Competition shall follow the Penalty Shootout Competition Regulations laid down in the Rules of Hockey, as issued by the FIH.

One-Day Tournaments

15.12. Format of play

- (a) The tournament shall be played in the format as designated by the Tournament Secretary or the Committee and notified to the Convenors of the participating teams.
- (b) If the format is in Round Robin format or include a Round Robin stage, points will be awarded as follows:
 - (i) Winner: Three (3) points
 - (ii) Score Draw: Two (2) points
 - (iii) No score Draw: One (1) point
 - (iv) Loss: Zero (0) points
- (c) If there is a tie at the end of the Round Robin stage, the ranking will be decided according to the following criteria (in order):
 - (i) matches won
 - (ii) respective goal difference (i.e. goals for less goals against)
 - (iii) respective number of goals for
 - (iv) the result of the match played between those teams will determine the ranking of the tied teams

- (d) If there is still a tie after considering the above, a Penalty Shootout will be taken to determine the ranking.
- (e) If the tournament is played in two (2) Pools, the first stage will be single Round Robin (points and ranking will be determined as stipulated in Bye-law 15.12 (b) and (c) where the top two (2) teams of each Pool after the Round Robin stage shall enter into the semi-finals.
- (f) If there is a draw in a semi-final, a Penalty Shootout will be taken to decide the winner.
- (g) If there is a draw in the final, a Penalty Shootout will be taken to decide the winner.

15.13. Penalty Strokes, Penalty Corners and Penalty Shootouts

Penalty strokes, penalty corners and penalty shootouts will be taken in accordance with the Rules of Hockey and Tournament Regulations, as issued by the FIH and with such amendments as may be deemed necessary by Tournament Secretary or the Committee, taking into account the venue and facilities available.

15.14. Teams

- (a) **‘Hockey5s’:** Teams shall consist of not more than ten (10) players, but not more than five (5) players of each team shall be on the field at the same time.
- (b) **7-a-side Tournaments:** Teams shall consist of not more than eleven (11) players, but not more than seven (7) players of each team shall be on the field at the same time.
- (c) **9-a-side Tournaments:** Teams shall consist of not more than fourteen (14) players, but not more than nine (9) players of each team shall be on the field at the same time.
- (d) **11-a-side Tournaments:** Teams will consist of not more than sixteen (16) players, but not more than eleven (11) players of each team shall be on the field at the same time.

15.15. Substitutions can be made at any time during the game and must be in accordance with Rule 2.3 of the current edition of the Rules of Hockey, as issued by the FIH.

15.16. Players listed to play in a one-day tournament must provide photographic identification to the officials and/or Umpires before the start of the tournament.

15.17. Duration of play

- (a) Pool matches, matches in Round Robin format and semi-finals shall be twelve (12) minutes one way or as scheduled by the Tournament Secretary.

- (b) If the tournament is played in Pool format, the final shall be ten (10) minutes each way, with two (2) minutes allowed for change of ends or as scheduled by the Tournament Secretary.
- 15.18. All teams must be at the pitch at the designated time (which will be no less than half an hour before the first game) to complete the registration process and be ready for the start of the first game. Captains must hand in completed tournament registration cards to the tournament facilitator(s) prior to the commencement of the first match in their Pool.
- 15.19. The tournament shall start on time and no grace period shall be given unless it is deemed necessary by the tournament facilitator(s).
- 15.20. Any team not showing up with a minimum of eight (8) players in the case of 11-a-side tournaments, a minimum of seven (7) players in the case of 9-a-side tournaments, a minimum of six (6) players in the case of 7-a-side tournaments and a minimum of four (4) players in hockey5s tournaments for their matches on time will forfeit their participation in the tournament and the results of their games will not be counted.
- 15.21. The first named team shall defend the north end of the pitch and shall have the push back, or in the final of a Pool format, the first push back.
- 15.22. Each team must provide Umpire(s) according to the schedule issued by the Tournament Secretary or the HKHAWs.
- 15.23. In the event of a kit clash, the second named team must change to their full second strip or must change to their second strip shirt or their second strip socks, as necessary, to avoid any clash of colours.
- 15.24. The Tournament Secretary or the tournament facilitator(s) shall have the authority to arbitrate any disputes.
- 15.25. Where 'hockey5s' is played, the rules shall follow the current edition of the Rules of Hockey5s, as issued by the FIH, unless otherwise specified by the Tournament Secretary.

16. MISCONDUCT, COMPLAINTS AND APPEALS

- 16.1. All officials, players and spectators participating in or at hockey matches held under the auspices of the HKHA shall be governed by the:
- The Rules of Hockey as from time to time made by the FIH;
 - Rules of the HKHA;
 - Bye-laws of the relevant Section of the HKHA; and
 - The HKHA Code of Conduct,

each of which may be downloaded from the websites of the FIH or the HKHA (as applicable).

- 16.2. All cases of misconduct shall be dealt with in accordance with Rules of the HKHA and/or Bye-law 14 of the HKHAWS General Bye-laws.

Yellow Card Penalty Points

- 16.3. A player receiving a yellow card shall receive penalty points as per Third Schedule.

Red Card Penalty System

- 16.4. A player awarded with a red card shall leave the field of play immediately (staying at the team bench is not permitted) and receive automatic suspension and penalty points as per Third Schedule.
- 16.5. Affiliated Clubs are responsible to ensure their player having received a red card observe the immediate suspension and does not take part in any match during the period of the two (2) match suspension.
- 16.6. All red card offences will automatically be investigated by the HKHAWS for misconduct and, where necessary, the case may be referred to the DC for further review. Suspensions received in the latter weeks of the season will carry forward if there are insufficient matches left to serve the suspension.
- 16.7. Complaints by an Affiliated Club against officials, players or spectators of another Affiliated Club shall be made, in writing, within forty-eight (48) hours, to the Secretary of the HKHAWS.
- 16.8. When the Committee receives reports or video-evidence from Umpires, Team Captains or Convenors regarding serious misconduct of players during the match regardless whether the players involved have been carded, the Committee will conduct investigations if needed to determine whether these players have breached any rules and bye-laws as stipulated in 16.1. Should the Committee find these misconducts have brought the game of hockey into disrepute, it will take necessary disciplinary actions against the players and/or the Affiliated Clubs involved according to the Bye-law 14 of the HKHAWS General Bye-laws.
- 16.9. In the event that a player of:
- (a) an Affiliated Club is suspended from hockey, that player is automatically debarred from playing for her Club team(s) as well as for any other HKHA Team during the period of suspension. i.e. a two-match suspension means the next two (2) matches of the team for which the player was playing when the red card was awarded. The two-match suspension cannot be a combination of one (1) Club match and one HKHA Team match (or in respect of the suspension of a Nominated Player, a combination two (2) Club matches of the two (2) different teams for which she is registered).
 - (b) a HKHA Team is suspended from hockey, that player is automatically debarred from playing for any HKHA Team as well as for her Club team(s) during the period of suspension. i.e. a two-match suspension means the next two (2) matches of the HKHA Team for which the player was playing when the red card was awarded. The two-match suspension cannot be a

combination of one (1) Club match and one (1) HKHA Team match (or in respect of the suspension of a Nominated Player, a combination two (2) Club matches of different teams). If, during the period of suspension, her Club team has played two (2) matches (or in respect of the suspension of a Nominated Player, one of her Club teams has played two (2) matches), she may then play for either of her Club team(s) even though she may still be suspended from playing for her HKHA team.

- 16.10. Other contravention of these Bye-laws shall be dealt with as specified in the Bye-laws themselves, with reference to the Second Schedule, or by the Committee.
- 16.11. All appeals shall be dealt with in accordance with Rule 4 of the HKHA and/or Bye-law 15 of the HKHAWS General Bye-laws.

17. RESPONSIBILITY OF TEAMS TO PROVIDE UMPIRES

- 17.1. Teams accepted for participation in HKHA matches shall be required, from time to time to provide Umpires to officiate at matches allocated to them. It is the responsibility of such designated teams to provide properly registered Umpires and to ensure that their nominated Umpires turn up to officiate at matches so allocated.

Contravention

- 17.2. A penalty, as specified in the Second Schedule, shall be levied for a contravention of this Bye-law.

18. ADVERTISING ON UNIFORMS

- 18.1. Advertising in the form of a company's name, logo or trademark is permitted when expressly authorised by the HKHAWS.
- 18.2. The size and positions of advertising follow the “**2012 – Uniform Advertising Regulations**” laid out in the FIH Regulations & Policies as issued by the FIH.
- 18.3. All measurements are taken as the area within a rectangle drawn around the advertisement. Permitted positions are as per the Fourth Schedule.
- 18.4. The prior written approval of the HKHAWS is required before an Affiliated Club can accept any sponsorship. The Affiliated Club is required to provide the HKHAWS with images or diagrams of the proposed advertisement(s) and await the approval of the HKHAWS before it enters into any sponsorship agreement.
- 18.5. Should an approval become out of date because a sponsor contract has expired, the Affiliated Club is not required to inform the HKHAWS. However, any changes to approved advertisement(s) or new advertisement(s) must be approved by the HKHAWS before use.
- 18.6. No advertisement will be permitted that is deemed by the HKHA to be detrimental to the positive image of the match.

- 18.7. The advertisement shall not in any way conflict with any code of ethics issued by the HKHA.
- 18.8. No tobacco or alcohol advertising shall be permitted with the exception of beer advertising which shall be permitted only in activities organised primarily for adults (e.g. Men's, Women's and Mixed leagues, Cup competitions and Tournaments). No beer advertising will be permitted in activities organised for young people under the age of 18 (e.g. Youth League, Mini Hockey).
- 18.9. No Club may use the Hong Kong flag/national emblem unless permission/approval in writing from the Government regarding usage of the HKSAR logo has been sought and received. Any such approval should be submitted with the uniform design.

Contravention

- 18.10. Clubs contravening any of the above Bye-laws will be liable to a fine to be determined by the HKHAWS.

19. CHARGES AND LEVIES

- 19.1. The Committee may, from time to time, be obliged to raise levies on teams and/or players registered with them.
- 19.2. Payment of any fees, disciplinary fines or levies should be made upon demand.
- 19.3. Invoices not paid one (1) month after the due date will be subject to a penalty.
- 19.4. Teams or players with overdue fees, fines or levies may, at the discretion of the HKHAWS Committee, be excluded from active participation in any hockey event until such time as full payment, including any penalty added, is made.

Contravention

- 19.5. A penalty, as specified in the Second Schedule, shall be levied for a contravention of these Bye-laws.

20. TROPHIES

- 20.1. All trophies won from any leagues, cups, festivals or tournaments organised by the HKHAWS shall remain the property of the HKHAWS.
- 20.2. Trophies shall be kept with HKHAWS or may be released to Affiliated Clubs on the condition that the trophies are signed out and returned upon request by the HKHAWS.
- 20.3. Once a trophy has been released to an Affiliated Club, the Affiliated Club shall take full responsibility for that trophy and will be liable for any cost incurred as a result of loss or damage to that trophy.

Contravention

- 20.4. A penalty, as specified in the Second Schedule, shall be levied for a contravention of these Bye-laws.

21. UNFORESEEN EVENTS

- 21.1. Should circumstances arise which are not provided for in these Bye-laws, the Committee shall determine any actions necessary to deal with those circumstances.

1. FIRST SCHEDULE

Bye-law 5.1	Player Registration Fee	\$300 per additional player if total registered players exceeds 22
Bye-law 6.1	Visiting Player Registration Fee	\$300 per player
Bye-law 8.3	Player Transfer Fee	\$300 per player per transfer
Bye-law 11.9	Match Postponement / Bringing Forward Fee	\$1,000 per request

SECOND SCHEDULE

Bye-law 5	Unregistered Player	<p>First contravention:</p> <ul style="list-style-type: none">• forfeiture of match *• deduction of one (1) league point• the player involved will be suspended for two (2) matches upon registration• the Team Captain of the team using the unregistered player will be suspended for one match <p>Second contravention:</p> <ul style="list-style-type: none">• forfeiture of match *• fine of \$500 per player per contravention• deduction of three (3) league points• the player involved will be suspended for two (2) matches upon registration• the Team Captain of the team using the unregistered player will be suspended for one (1) match <p>Subsequent contraventions:</p> <ul style="list-style-type: none">• forfeiture of match *• fine of \$1,000 per player per contravention• deduction of five (5) league points• the player involved will be suspended for two (2) matches upon registration• the Team Captain of the team using the unregistered player will be suspended for one (1) match
Bye-law 6	Visiting Players	<p>First contravention:</p> <ul style="list-style-type: none">• forfeiture of match *• deduction of one (1) league point• the player involved will be suspended for two (2) matches• the Team Captain of the team using the visiting player will be suspended for one (1) match <p>Subsequent contraventions:</p> <ul style="list-style-type: none">• forfeiture of match *• fine of \$500 per player per contravention• deduction of three (3) league points• the player involved will be suspended for three (3) matches• the Team Captain of the team using the visiting player will be suspended for two (2) matches

Bye-law 7	Player Movement	<p>First contravention:</p> <ul style="list-style-type: none"> • forfeiture of match * • the player involved will be suspended for one (1) match <p>Second contravention:</p> <ul style="list-style-type: none"> • forfeiture of match * • fine of \$500 per player per contravention • deduction of one (1) league point • the player involved will be suspended for one (1) match • the Team Captain of the team will be suspended for one (1) match <p>Subsequent contraventions:</p> <ul style="list-style-type: none"> • forfeiture of match * • fine of \$500 per player per contravention • deduction of three (3) league points • the player involved will be suspended for one (1) match • the Team Captain of the team will be suspended for one (1) match
Bye-law 9	Player Uniform	<p>First contravention:</p> <ul style="list-style-type: none"> • \$100 per player per contravention <p>Subsequent contraventions:</p> <ul style="list-style-type: none"> • \$500 per player per contravention
Bye-law 11.2	Late Start	\$500 per contravention per match
Bye-law 11.3	Walk-Off / Refusal to Play	<ul style="list-style-type: none"> • forfeiture of match * • fine of \$500 • any further penalty imposed by the Committee or the Disciplinary Committee after investigation of the incident
Bye-law 11.4 & 11.6	Walkover	<p>Non Premier Division Teams</p> <p>First contravention:</p> <ul style="list-style-type: none"> • forfeiture of match • fine of \$500 <p>Second contravention:</p> <ul style="list-style-type: none"> • forfeiture of match • fine of \$1,000 • deduction of two (2) league points <p>Subsequent contraventions:</p> <ul style="list-style-type: none"> • forfeiture of match • fine of \$1,500 • deduction of four (4) league points • referral to Committee <p>Premier Division Teams</p>

		<p>First contravention</p> <ul style="list-style-type: none"> • forfeiture of match • fine of \$1,500 • deduction of four (4) league points • referral to Committee <p>Subsequent contravention</p> <ul style="list-style-type: none"> • Penalty as determined by the Committee
Bye-law 11.7	Withdrawal from the HKHA League or Knockout Tournaments	Penalty as determined by the Committee
Bye-law 13	Captains' Responsibilities	\$200 per contravention per match
Bye-law 14	Late Submission of Match Card	<p>First contravention:</p> <ul style="list-style-type: none"> • fine of \$500 <p>Subsequent contraventions:</p> <ul style="list-style-type: none"> • fine of \$500 • deduction of one (1) league point
	Non-receipt of Paper Match Card Within fourteen (14) Days of a Match	Fine of \$500 per contravention
	Incomplete/ inaccurate Information on Match Card	<p>First contravention:</p> <ul style="list-style-type: none"> • fine of \$500 <p>Subsequent contraventions:</p> <ul style="list-style-type: none"> • fine of \$500 • deduction of one (1) league point
	Failure to Provide Team's Player List and/or player photographic identification documents	<ul style="list-style-type: none"> • fine of \$100 per contravention per match on Team's Player List • fine of \$100 per player unable to provide photographic identification documents, up to a maximum of \$800 per match
Bye-law 15.2	Late withdrawal from Domestic Tournaments	<p>First contravention:</p> <ul style="list-style-type: none"> • fine of \$1,000 <p>Subsequent contraventions:</p> <ul style="list-style-type: none"> • fine of \$1,500
Bye-law 17	Failure to Provide Umpires	<p>First contravention:</p> <ul style="list-style-type: none"> • fine of \$500 <p>Second contravention:</p> <ul style="list-style-type: none"> • fine of \$500 <p>deduction of one (1) league point</p> <p>Subsequent contraventions:</p> <ul style="list-style-type: none"> • fine of \$1,000

Bye-law 18	Advertising on Uniform Without Approval	<ul style="list-style-type: none">• deduction of three (3) league points Penalty as determined by the Committee
Bye-law 19	Late Payment of Charges and Levies	Penalty as determined by the Committee
Bye-law 20	Lost Trophy	First offence: <ul style="list-style-type: none">• \$500 per trophy lost plus the cost of replacing a similar style trophy Subsequent offence: <ul style="list-style-type: none">• \$1,000 per trophy lost plus the cost of replacing a similar style trophy

* In games where the match score is greater than 0-4 the higher result shall stand.

THIRD SCHEDULE

YELLOW AND RED CARDS

Yellow Card Penalty Points

1. A player receiving a yellow card shall also receive penalty points as follows:

Y1 Dissent (continued contesting of umpires' decisions) – Two (2) points;

Y2 Dangerous Play (Continued or violent stick tackles, violent obstruction, continued and deliberate lifting of the ball) – Three (3) points;

Y3 Verbal Abuse of Umpire (use of foul language against the umpire(s) or continued and aggressive contesting of decisions of the umpire(s)) – Three (3) points;

Y4 Verbal Abuse of Player (use of foul language or continued and aggressive behaviour against another player(s)) – Two (2) points;

Y5 Threatened Assault on Umpire (Physical confrontation of the umpire by a player) – Four (4) points;

Y6 Threatened Assault on Player (Physical confrontation of a player by another player) – Three (3) points;

Y7 Others, state offence (Non-violent nature) – One (1) point

2. **PENALTIES**

5 points accumulated in one season – suspension for 1 match

10 points accumulated in one season – suspension for 2 matches

15 points accumulated in one season – suspension for 3 matches and referral to Disciplinary Committee.

Upon accumulation of 5 points, the subject player will be immediately suspended for 1 match (league or cup). If the accumulated points exceed 5 points (e.g. to 6 or 7 points) then once the player has completed her suspension, the player starts a new accumulation of points from 5 to 10. The additional points above 5 (i.e. 1 or 2 depending on the total accumulated) shall begin to count towards the next “level” total of 10 points starting from 5.

Example A player, who has accumulated 3 points, receives a yellow card with a code Y2 offence (3 points). The player now has accumulated 6 points. The player automatically is suspended for 1 match. Following the suspension, he begins to accumulate points in a new series of 5 up to 10, starting at 6 points. Should the player accumulate a further 4 points, he will be suspended for another two matches.

Suspensions under the yellow card penalty points system shall be served upon the notification by the HKHAMS. Points left over from one season will not be carried over to the following season. However, suspensions received in the latter weeks of the season will carry forward to the following season if there are insufficient matches left to serve the suspension.

3. Depending on seriousness of each reported case of yellow card, the Committee may:

- (a) take no further action, or
- (b) issue a letter of warning, or
- (c) interview and warn the player in person at a meeting; or
- (d) refer the case to the Disciplinary Committee should the offence bring the game of hockey into disrepute.

Red Card Penalty System

16.5 A player awarded with a red card shall leave the field of play immediately (staying at the team bench is not permitted) and receive automatic suspension as follows:

R1 Repeated Dissent – suspension for 2 matches

R2 Second offense of dangerous play or very dangerous play – suspension for 3 matches

R3 Repeated verbal abuse or foul abuse of umpire – suspension for 4 matches

R4 Repeated verbal abuse or foul abuse of another player – suspension for 2 matches

R5 Repeated threatened assault or physical assault of umpire – suspension for 5 matches

R6 Repeated threatened assault or physical assault of another player – suspension for 4 matches

R7 Others, state offence (non-violent nature, repeated offence of Y7) – suspension for 2 matches

FOURTH SCHEDULE

ADVERTISING ON UNIFORMS

Diagrams showing the positions allowed for advertisement

SHIRT (FRONT)

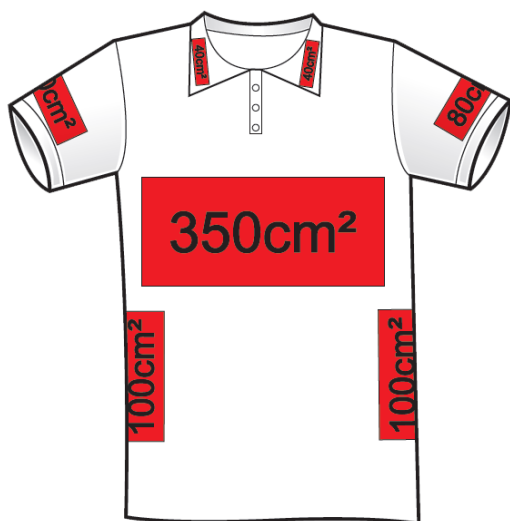

SHIRT (BACK)



OR



OR

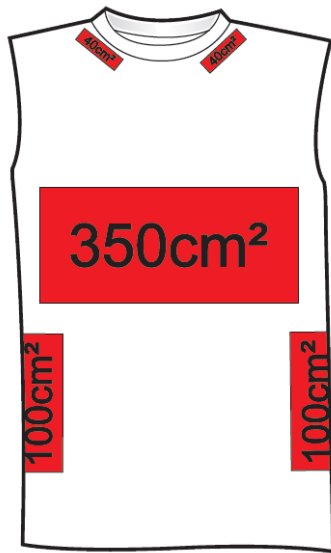

SHORT/SKIRT (FRONT)

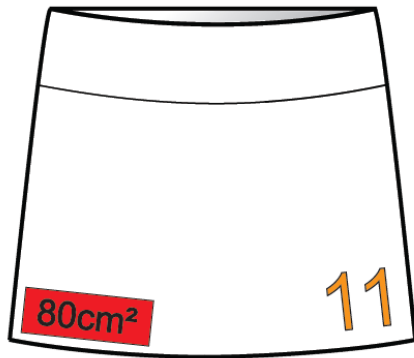

OR

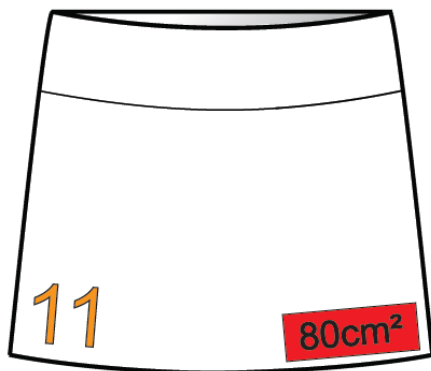

SHORT/SKIRT (BACK)

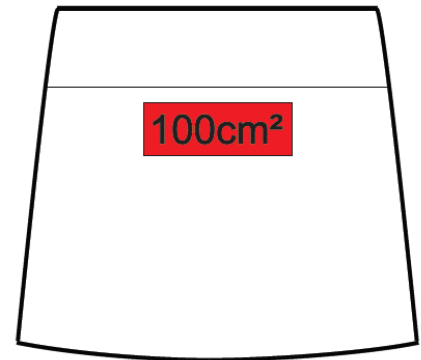

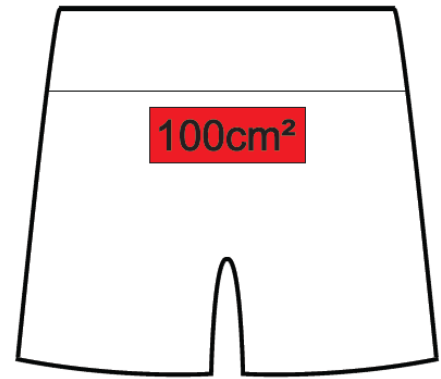
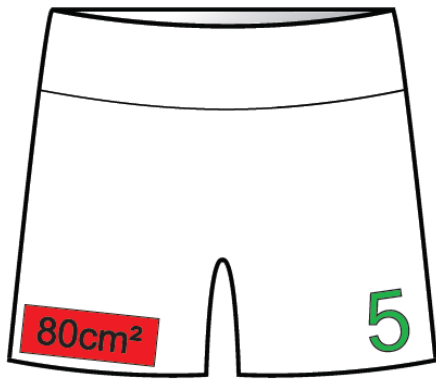

OR

